

# Installation Instructions and techn. Documentation

## e-litro secu4

Electronic tank monitoring device (complete kit)

- for battery tanks
- incl. overfill safety
- after TRwS 791(-2) with clearance display



<u>Content:</u>	<u>Page:</u>
Labeling	1
Regulations	2
Principle Sketch	3
Mounting of Measuring Hoses	3
Electrical installation	4
Error Codes	6
Technical Data	7
Included Items	8
Maintenance	8
Disposal	8

### LABELING



The manufacturer TECSON declares the compliance with the valid safety and test guidelines (CE Declaration).  
For Conformity Declaration refer to website [www.tecson.de](http://www.tecson.de)  
at menu item Documentation

# REGULATIONS

## Installation and Mounting



The tank monitoring system **e-litro secu4** consists of two components, the displaying device and the sensorbox. Both e-litro devices are not viable for external installation (safety class IP50).

During the tank fuelling the **secu4** assists to avoid overfilling of the battery tank system. When a tank reaches its filling limit the **secu4** will generate a loud ALARM. With the option of the current loop connection box the **secu4** will interrupt the filling process automatically to prevent overfilling. Via relay circuit opening it interrupts the limiter current loop of the overfill protection.

The **secu4** does not replace but supports the limit indicator by monitoring the downstream battery tanks.



For installation and mounting of the devices mentioned above please follow the conditions of the respective manual. The corresponding safety instructions for electric devices and oil tanks need to be observed.

The startup is performed after successful mounting.

The displaying device of the **e-litro secu4** is applicable for liquid level measurements of tanks operated unpressurized. The main application are battery tank systems with up to 4 tanks (maximum display value: 10,000 liters per tank).

The sensorbox uses a bubbler level measurement system with up to 4 measuring hoses. The level measurement data gets analyzed and shown at the displaying device

To ensure an intended operation and a valid warranty the respective manual has to be obeyed and handed over to the operator. An improper installation causes the loss of warranty.



Installation and startup have to be performed by a qualified technician. Make sure to follow the regulations of the used liquid, especially for water endangering or flammable liquids.

To ensure a flawless operation of the device a proper installation in accordance with the rules for scheduling, construction and operating of the overall system is required. Therefore the accident prevention rules, the regulations of the German Electrical Engineering Association (VDE) and the operating instructions of the storage container need to be observed.

- The permissible surrounding temperature ranges from 5°C up to 40°C.
- The device is designed for an altitude up to 2000m.
- Mounting the device in an explosion-prone area is restricted.

### 230V AC Version:

The displaying device is connected to the power supply via NYM-J 3x1,5 (or equivalent) and must only be operated with the cover being closed. An easily accessible separate connection protection needs to be provided.

## PRINCIPLE SKETCH

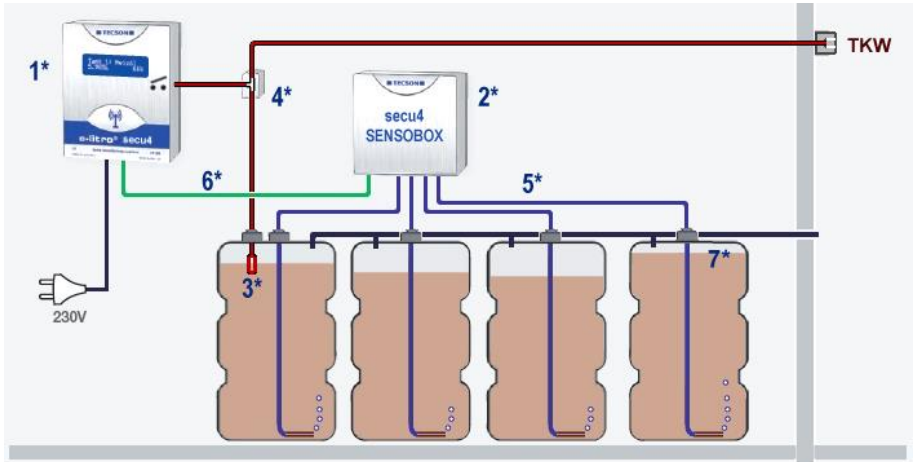

Legend:

**e-litro secu4** for battery tank system monitoring

- 1\* Display and Warning Device secu4.
- 2\* Sensorbox: Measurement recorder with 4 connections for air bubbler hoses.
- 3\* Limit indicator in the first battery tank.
- 4\* (Optional) Limit Indicator Connection Box with relay to break the limit indicator current loop.
- 5\* Measuring hoses to the single tanks (up to 4 measuring hoses connectable).
- 6\* Data line from the sensorbox to the displaying device (3 wire cable, 50m prolongable).
- 7\* Tank level (in Fig.: in case of parallel filling -> risk of overflowing tank 4).

## MOUNTING OF MEASURING HOSES



**Mounting of the air bubbler hoses:**

- Drill a 9 mm hole.
- Slide the grommet over the measuring hose by using a lubricant.
- Insert the measuring hose into the drilling hole with the brass sinker to the front.
- **Add about 1/2 m of the measuring hose so that the brass sinker will lay down horizontally at the bottom of the tank**
- Firmly press the **grommet** into the drilling hole (odour-proof).

## Measuring Hose Connection to the Sensorbox



### Connection of Measuring Hoses:

- Connect the measuring hose of the first tank to the leftmost pressure measurement input. Insert about 1 cm.
- Connect the measuring hose of the second tank to the input second from left.
- If required do the same procedure for Tank3 and Tank4.
- **To unfasten the measuring hose press the blue ring.**

## Electrical Installation

### Connection for the [secu4](#) Displaying Device 1\*



1. Left clamping block:
  - Data input from sensorbox  
cl.1 white, cl.2 green, cl.3 brown
2. Clamping block next to it:
  - Serial data output at clamp 4+5  
for PC-LINK or e-litro/gsm or GSM- Messenger
3. Clamping block at the top right:
  - Relay switch output at clamp 6+7  
interrupts the current loop when filling limit is reached. The relay can also be programmed as a switch normally open (see menu item 7)
4. Clamping block at the bottom right : N+L
  - Power supply 230V AC  
It is recommended to tap the phase and neutral wire from a junction box and wire it to the device (Make sure to turn off the line current! Follow the regulations for electrical installation)

The control keys are located at the left hand side of the transformer.

Optional: **Connection box for current loop interruption 4\***

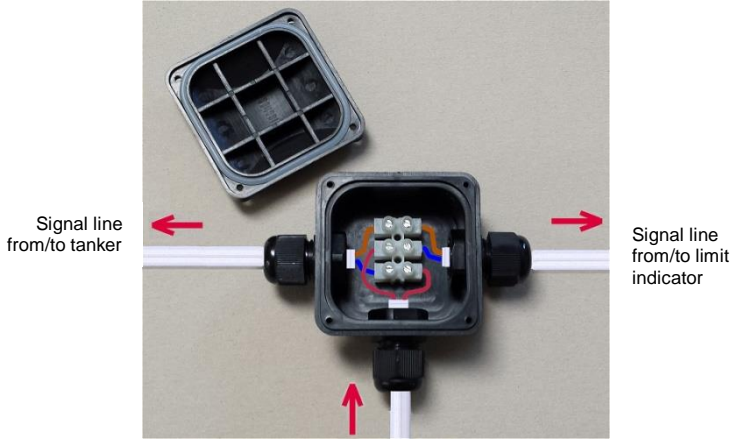

Release signal from secu4 relay: Separate the limit indicator signal line and and interpose the relay (Cl. 6+7) inside the secu4 device at one of the limit indicator cores.

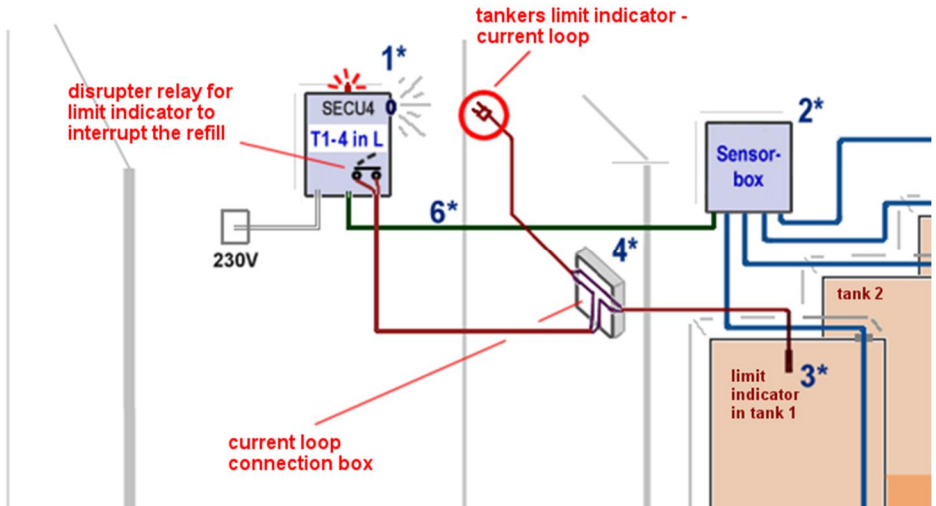

## ERROR CODES

Error <b>E 1</b>	Invalid input value.
Error <b>E 2</b>	Signal value of the LITRO-sensor is too small (signal current less than 3.7 mA). In case of the secu4 the sensorbox transmits invalid data (probe error). Disconnect the current supply and turn the device back on. If the error lasts for at least 5 min. the LITRO-sensor or the sensorbox is defective.
Error <b>E 3</b>	Measuring value of the LITRO-sensor is too high for offset calibration. The probe must not be plunged! A probe current of 4.5 mA or higher indicates a problem with the probe.
Error <b>E 4</b>	Measured value is implausible. Perform menu item <b>Ø</b> . Offset probeq
Error <b>E 5</b>	Height input is larger than tank height. (Wrong input)
Error <b>E 6</b>	The measured value is too small for reference. Make sure the probe is plunged. The appointed height is too big or the measuring value (resp. the filling level) is too small for setting. Perform step <b>Ø</b> . Offset probeq Otherwise probe error.
Error <b>E 7</b>	The measured value is too small for the appointed tank height or tank volume. Make sure the probe is plunged!
Error <b>E 8</b>	The high test pressure during the <u>maintenance check</u> (s. page 20) was fully reached. This was the aim of the test, <u>no error exists</u> .
Error <b>E 9</b>	The current value is 0 mA. The probeq connection could be broken. Check probe connection (polarity) and extension and if necessary reconnect it.
Error <b>E10</b>	Calibration error. Switch off and on the 230V supply voltage after waiting for 5 sec and retry. Otherwise the LITRO-sensor or the sensorbox is defective.
Error <b>E11</b>	Warning: The liquid level of the tank is too low for an exact calibration (Press [Enter] to continue anyway).
Error <b>E12</b>	No measurement data is received yet from the external tanks 2, 3 or 4. In case of <b>secu4</b> the sensorbox has not sent any data yet. Wait for 3 min.
Error <b>E13</b>	No measurable pump pressure. Disconnect the current supply then reconnect it and wait for one pumping cycle. If the error E13 remains the micro pump is defective. Otherwise <u>send in</u> the LITRO-sensor or the sensorbox! The device is not repairable on site. <u>Do not open</u> the device, loss of warranty!
Error <b>E14</b>	Charging voltage is too low. Wait for 3 min. If necessary disconnect the power supply for 10s.
Error <b>E15</b>	No data from the sensorbox. Potential disruption of the sensorbox signal line.
Error <b>E16</b>	Implausible pressure drop of one of the tank measuring lines (please check!). Disconnect the power supply for 10s or <u>cancel E16 with OK</u> . Otherwise the sensorbox is defective.
Error <b>E18</b>	<b>Error indication during maintenance check:</b> The internal test pressure was not reached! The sensorbox of the secu4 or the LITRO-sensor has to be replaced.

## TECHNISCHE DATEN

Supply voltage:	AC-Variant : 230 V 50 Hz DC-Variant* : 12V or 24V * = available on request.  Power line: NYM-J 3 x 1.5 mm <sup>2</sup>	RECOMMENDATION: For a constant power supply connect the device to the connection box via L/N. The power line needs to be fused separately.  For exceptional cases a power plug wire for wall sockets is enclosed.
Power Consumption:	<= 2 VA in continuous operation.	
Measuring Principle:	Fully automatic bubble pressure method (electronic-pneumatic)	
Pneumatic Bubble Pressure Lines	Measuring hoses made of PUR (flexible), ballasted with a brass casing. Length of measuring hoses: 2 x 5.50m and 2 x 7.50m (prolongable).	
Relay Outputs:	Switching output of the relay, floating. Setting $\varnothing$ opening relay $\pm$ Interrupts above the filling limit. Alternatively the $\varnothing$ losing relay $\pm$ function can be set (menu item 7). Relay switching voltage: max. 250 V AC Relay switching current: max. 3,5 A Also suited for low-voltage, e.g. limit indicator current loop.	
Data Output:	Serial Link Output for data transfer (Tecson Link interface). Unscreened wire length up to 50m, screened wire length up to 200m	
Signalling Cable from Sensorbox to secu4	3-wire cable (white=plus ; green=data ; brown=minus), 6m length. Left clamping block (1,2,3), prolongable up to 50m.	
Housing Dimensions WxLxH	Housing protection class: IP 50 Displaying device: polystyrene a. acrylic glass. 120 x 145 x 50 mm (x,y,z) Sensorbox: ABS plastic 120 x 150 x 60 mm Current loop connection box ABS und polyamide (PA6) 145 x 110 x 45 mm	

### Measured Media

<b>Non-aggressive liquids</b> at surrounding temperature. Wetted materials are the measuring hoses made of PUR and the brass weights.	
<b>Heating oil</b>	<i>by DIN 51603-1</i>
<b>Diesel fuel DK</b>	<i>by DIN EN 590</i>
<b>Biodiesel</b>	<i>by DIN EN 14214</i>
<b>Petroleum</b>	
<b>Vegetable oil</b>	<i>The device has no suitability test for groceries.</i>
<b>Motorenöl</b>	
<b>Wasser</b>	<i>Or other watery non-aggressive liquids.</i>
<b>Andere</b>	<b><i>Only after consultation.</i></b>

## Delivery Contents

Complete set <b>İe-litro secu4İ</b> : article No. 13044	
<ul style="list-style-type: none"> <li>▪ <b>Displaying device secu4</b></li> </ul>	<ul style="list-style-type: none"> <li>- 4 wall plugs and screws for wall mounting</li> <li>- 1 power plug wire for power supply via wall socket</li> </ul>
<ul style="list-style-type: none"> <li>▪ <b>Sensorbox</b></li> </ul>	Measurement recording device (included in the set) <ul style="list-style-type: none"> <li>- 6m signal cable to the displaying device, prolongable</li> <li>- 2 pipe clips for mounting at the oil suction tube</li> <li>- 4 measuring hoses, 5.5m to 7.5m long</li> <li>- 4 rubber sealing grommets (for seal of measuring hoses).</li> </ul> - art. No. 13045 - order number for spare parts.
<ul style="list-style-type: none"> <li>▪ <b>Current loop connection box</b></li> </ul>	Interpose box (included in the set) <ul style="list-style-type: none"> <li>- Connection box for the current loop disruption via relay output contact</li> </ul> - art. No. 13048 - order number for spare parts..

### Maintenance:



- Manufacturer's specification: Perform hardware maintenance at every tank or boiler maintenance. After expiration of the warranty period perform maintenance 1 x per year.
- Check the relay switching function via menu item 23 Test relayq
- For the measurement value test the filling level of the tank needs to be determined and compared to the displayed value (cm).  
Valid measurement variation <= 2% of a full tank.



- **Additionally for secu4:**

Crease and hold the measurement hose of tank 1 until the sensorbox has completed its pumping processō

Check: The display has to show Error **E008!** => Test successful (OK).  
If Error **E018** is shown => Test not successful!  
In that case please send in the sensorbox for exchange.

### Disposal:



After dismantling all parts need to be disposed properly with regard to their material.  
Dismantled parts do not belong in the household refuse but to the local recycling yard

### Manufacturer:

**TECSON GmbH & Co. KG**

Wulfsfelder Weg 2a  
D-24242 Felde

Tel. (+49) 4340 / 402530  
Fax (+49) 4340 / 402529

WEEE no. DE 18639642

[www.tecson.de](http://www.tecson.de)  
[info@tecson.de](mailto:info@tecson.de)